

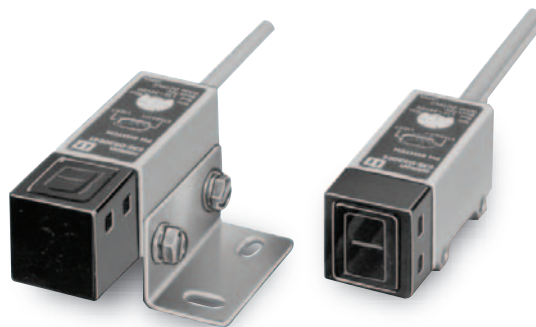

## General-purpose Photoelectric Sensor for High Quality and Reliable Detection



















 Be sure to read *Safety Precautions* on page 8.

Note: E3S-2/-5/-DS10/-DS30/-R2 in this catalog have been discontinued at the end of March 2014.

### Ordering Information

#### General-purpose Sensors

Sensing method	Appearance	Sensing distance	Operation mode	Model
Convergent-reflective (narrow vision field)		 30 to 100 mm (variable)	Light-ON/Dark-ON (selectable)	<b>E3S-LS10XE4 2M</b>
Convergent-reflective (wide vision field)		 50 to 250 mm (variable)		<b>E3S-LS20XE4 2M</b>
Through-beam		 2 m		<b>E3S-2E4 *</b> Emitter E3S-2LE4 * Receiver E3S-2DE4 *
		 5 m		<b>E3S-5E4 *</b> Emitter E3S-5LE4 * Receiver E3S-5DE4 *
Retro-reflective		 0.1 to 2 m		<b>E3S-R2E4 *</b>
Diffuse-reflective		 100 mm		<b>E3S-DS10E4 *</b>
	 300 mm	<b>E3S-DS30E4 *</b>		
Through-beam		 2 m		<b>E3S-2E41 *</b> Emitter E3S-2LE41 * Receiver E3S-2DE41 *
		 5 m		<b>E3S-5E41 *</b> Emitter E3S-5LE41 * Receiver E3S-5DE41 *
Retro-reflective		 0.1 to 2 m		<b>E3S-R2E41 *</b>
Diffuse-reflective		 100 mm		<b>E3S-DS10E41 *</b>
	 300 mm	<b>E3S-DS30E41 *</b>		

\* Production was discontinued.

## Ratings and Specifications

Sensing method  Model  Item	Through-beam		Retro-reflective	Diffuse-reflective			Convergent-reflective		
	E3S-2E4 E3S-2E41	E3S-5E4 E3S-5E41	E3S-R2E4 E3S-R2E41	E3S-DS10E4 E3S-DS10E41	E3S-DS30E41	E3S-DS30E4S	E3S-LS10XE4	E3S-LS20XE4	
<b>Sensing distance</b>	2 m	5 m	0.1 to 2 m	100 mm (white paper 50 x 50 mm)	300 mm (white paper 100 x 100)		30 to 100 mm Continuously variable (10 x 10 mm)	50 to 250 mm Continuously variable (50 x 75 mm)	
<b>Standard sensing object</b>	Opaque: 7- mm dia. min.	Opaque: 11- mm dia. min.	Opaque: 30- mm dia. min.	Transparent, opaque					
<b>Differential travel</b>	---			20% max. of setting distance			1.5 mm max. at 30 mm	5% max. at 50 to 250 mm	
							10 mm max. at 100 mm		
<b>Directional angle</b>	Both emitter and receiver: 3° to 10°		3° to 10°	---					
<b>Light source (wavelength)</b>	Infrared LED (950 nm)						RED LED (660 nm)	Infrared LED (950 nm)	
<b>Power supply voltage</b>	12 to 24 VDC ±10%, ripple (p-p): 10% max.								
<b>Current consumption</b>	50 mA max. (Emitter: 25 mA max., Receiver: 25 mA max.)		40 mA max.						
<b>Control output (solid-state output)</b>	Output current: 1.5 to 4 mA, Load current: 80 mA max. (residual voltage: 2 V max.) → Refer to page 4.								
<b>Response time</b>	Operate or reset: 3 ms max.		Operate or reset: 1 ms max.						
<b>Sensitivity adjustment</b>	With an indicator								
<b>Ambient illumination (Receiver side) *</b>	Incandescent lamp: 3,000 lx max. Sunlight: 10,000 lx max.								
<b>Ambient temperature</b>	Operating: -25 to 55°C, Storage: -40 to 70°C (with no icing or condensation)								
<b>Ambient humidity</b>	Operating: 35% to 85%, Storage: 35% to 95% (with no condensation)								
<b>Insulation resistance</b>	20 MΩ min. at 500 VDC								
<b>Dielectric strength</b>	1,000 VAC, 50/60 Hz for 1 min								
<b>Vibration resistance (destruction)</b>	10 to 55 Hz, 1.5-mm double amplitude for 2 hours each in X, Y, and Z directions								
<b>Shock resistance (destruction)</b>	500 m/s <sup>2</sup> 3 times each in X, Y, and Z directions								
<b>Degree of protection</b>	IEC IP65	IEC IP67		IEC IP65	IEC IP67				
<b>Connection method</b>	Pre-wired cable (standard length: 2 m)								
<b>Indicators</b>	Light indicator (red), Stability indicator (green)								
<b>Material</b>	<b>Case</b>	Polybutylene terephthalate	Zinc die-cast		Polybutylene terephthalate	Zinc die-cast			
	<b>Lens *</b>	Polycarbonate							
	<b>Mounting Bracket</b>	Iron							

\* The ambient operating illumination is the illumination that changes the output ±20% at 200 lx. It is not the operational limit.

## Engineering Data (Reference Value)

### Parallel Operating Range

E3S-2E4 (41)

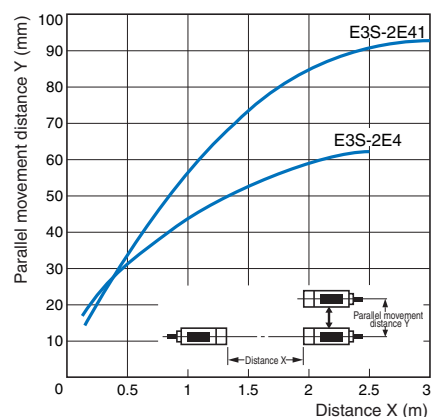

E3S-5E4 (41)

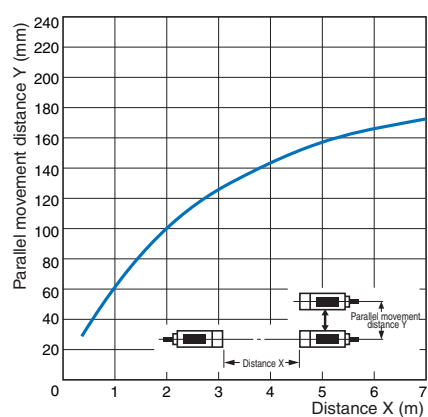

### Operating Range

E3S-DS10E4 (41)

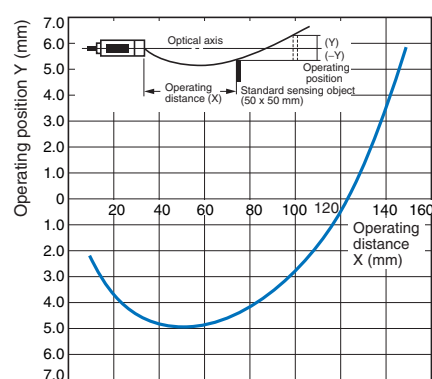

E3S-DS30E4 (41)

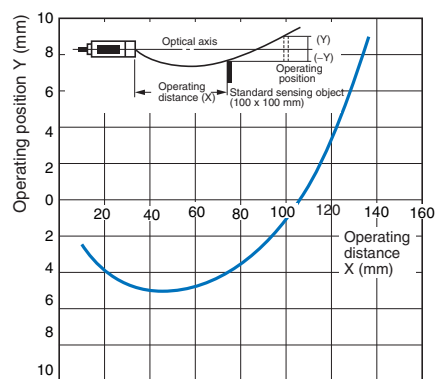

E3S-LS10XE4

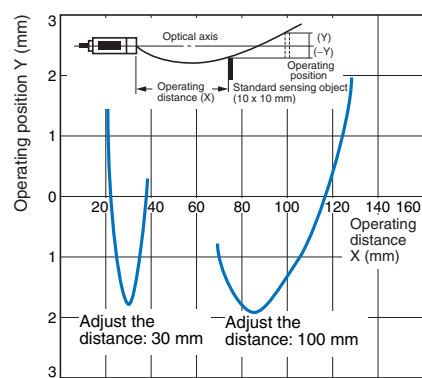

E3S-LS20XE4

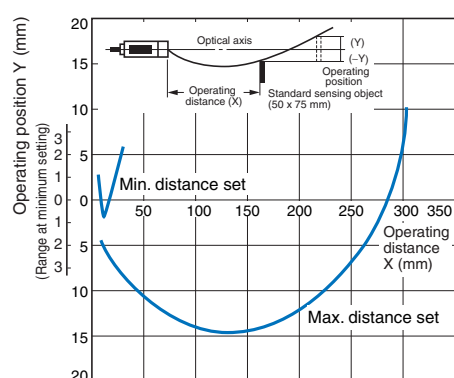

**Sensing Distance vs. Size of Sensing Object**

**E3S-DS30E4 (41)**

**E3S-DS10E4 (41)**

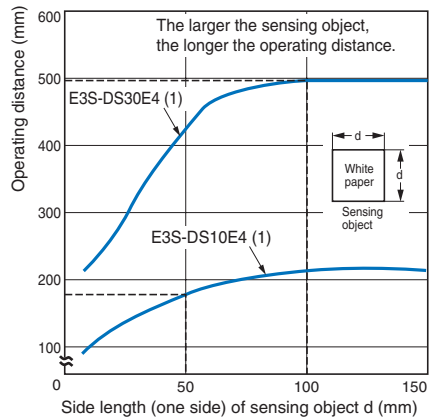

**E3S-LS20XE4**

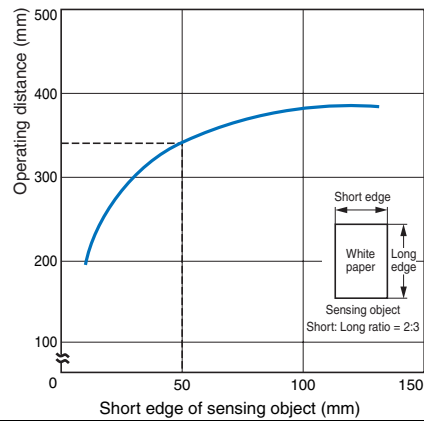

**Parallel Operating Range**

**E3S-R2E4 (41) (42)**

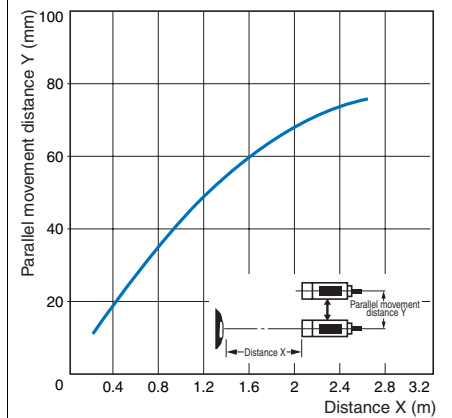

**Excess Gain vs. Set Distance**

**E3S-LS10XE4**

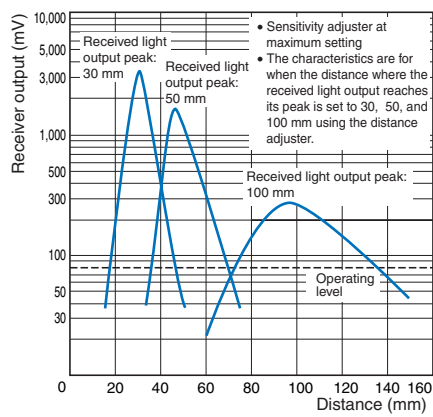

**E3S-LS3RC4**

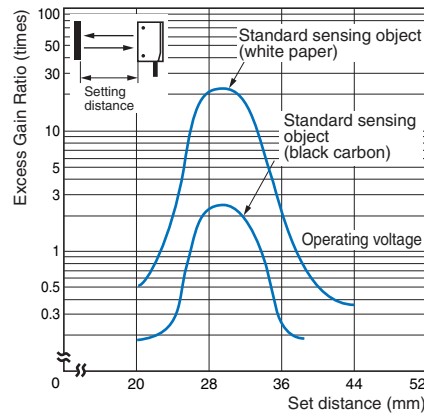

**Load Residual Voltage Characteristics**

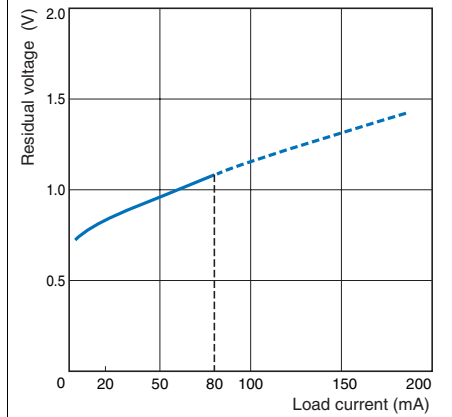

I/O Circuit Diagrams

Model	Wire color	Item Power polarity	Operation mode	Output circuit	Timing charts
E3S	Brown	+	Light-ON	<p>Z: Zener diode (<math>V_z = 30\text{ V}</math>)                      *1: Reverse the polarity of the power supply to switch the operating mode.                      *2: Voltage output (when connecting transistor circuit)</p>	Incident light: ON (High pulse) No incident light: OFF (Low) Light indicator (red): ON (High pulse) OFF (Low) Output transistor: ON (High pulse) OFF (Low) Load 1 (e.g., relay): Operate (High pulse) Reset (Between brown and black) Load 2: H (High pulse), L (Low pulse)
	Blue	0 V			Incident light: ON (High pulse) No incident light: OFF (Low) Light indicator (red): ON (High pulse) OFF (Low) Output transistor: ON (High pulse) OFF (Low) Load 1 (e.g., relay): Operate (High pulse) Reset (Between brown and black) Load 2: H (High pulse), L (Low pulse)
	Brown	0 V	Dark-ON	<p>Z: Zener diode (<math>V_z = 30\text{ V}</math>)                      *1: Reverse the polarity of the power supply to switch the operating mode.                      *2: Voltage output (when connecting transistor circuit)</p>	Incident light: ON (High pulse) No incident light: OFF (Low) Light indicator (red): ON (High pulse) OFF (Low) Output transistor: ON (High pulse) OFF (Low) Load 1 (e.g., relay): Operate (High pulse) Reset (Between blue and black) Load 2: H (High pulse), L (Low pulse)
	Blue	+			Incident light: ON (High pulse) No incident light: OFF (Low) Light indicator (red): ON (High pulse) OFF (Low) Output transistor: ON (High pulse) OFF (Low) Load 1 (e.g., relay): Operate (High pulse) Reset (Between blue and black) Load 2: H (High pulse), L (Low pulse)

## Connection

### ● With Relay Load

#### Through-beam Sensors

Light Interrupted and Load Operating for E3S-2E4 (41) and -5E4 (41)

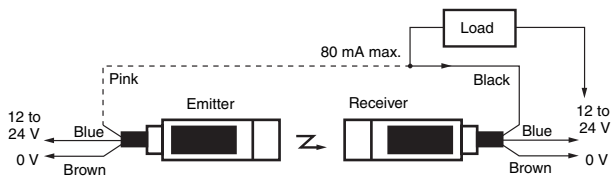

Note: The indicator will function as a light indication if the Emitter's pink wire is connected to the Receiver's black wire as indicated by the dotted line. The indicator will function as a power indicator if the Emitter's pink wire is connected to the Emitter's blue wire.

#### Retro-reflective Sensors

Light Interrupted and Load Operating for E3S-R2E4 (41) (42), -DS10E4(41), and -DS30E4 (41)

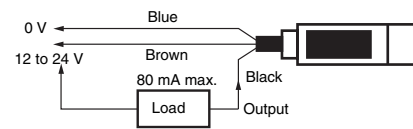

### ● Connection with S3D2 Sensor Controller

Reverse operation is possible using the signal input switch on the S3D2.

Sensing method	Through-beam	Reflective
Connection method		

## Adjustment Methods

### ● Adjusting the E3S-LS10XE4 Convergent-reflective Sensor

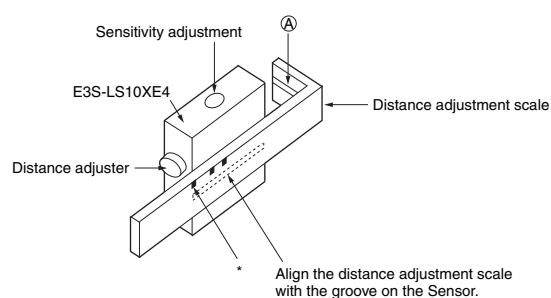

1. Attach the distance adjustment scale as shown in the figure and set it where the \* mark is equal to the sensing distance.
2. Turn the distance adjuster until the red spot is at point A (center of the distance adjustment scale).
3. Remove the distance adjustment scale once the distance has been adjusted. Put a sensing object in place, and then adjust the sensitivity.

### ● Adjusting the E3S-LS20XE4 Convergent-reflective Sensor

#### Adjustment Method 1

Use this method if the sensing object is more reflective than the background.

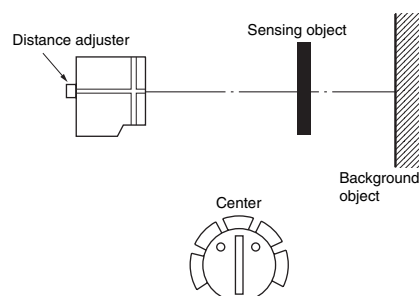

1. Set the sensitivity adjuster to the center as shown in the figure.
2. Turn the distance adjuster counterclockwise until it is fully turned (L to S).
3. Position the sensing object.
4. Slowly turn the distance adjuster clockwise (S to L).
5. Eventually the LIGHT (red) indicator will light. Turning the adjuster further will light the STABILITY (green) indicator. Leave the distance adjuster at this level.
6. Adjust the sensitivity in this state.

#### Adjustment Method 2

Use this method if the background is more reflective than the sensing object.

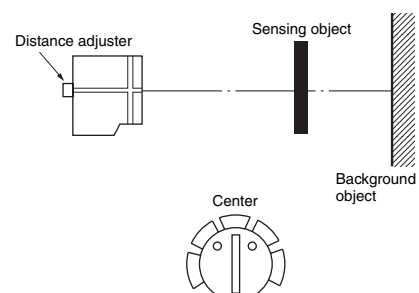

1. Set the sensitivity adjuster to the center as shown in the figure.
2. Turn the distance adjuster clockwise until it is fully turned (S to L).
3. Remove the sensing object.
4. Slowly turn the distance adjuster counterclockwise (L to S).
5. Eventually the LIGHT (red) indicator will light. Turning the adjuster further will light the STABILITY (green) indicator.
6. Adjust the sensitivity in this state.

## Safety Precautions

**⚠ WARNING**

This product is not designed or rated for ensuring safety of persons. Do not use it for such purposes.



**Precautions for Correct Use**

Do not use the product in atmospheres or environments that exceed product ratings.

If the sensing object has a metallic or shiny surface, the E3S-R may not detect it properly. To avoid this situation, place the sensing object so that it is not at right angles to the Photoelectric Sensor.

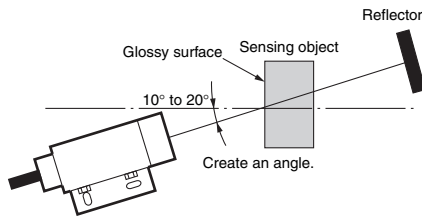

**● Attaching the E39-S Slit**

- The Slit can be fitted vertically or horizontally as indicated by the dotted line. Make sure that Slits for the Emitter and the Receiver are fitted in the same orientation.
- Place the packing in the supporter and hook the claws on the indentations in the Sensor head.
- If the supporter is contacting the mounting surface, insert a spacer to separate it. (Refer to *Slit Dimensions*.)
- An operating position accuracy of 0.1 mm max. can be achieved for a Through-beam Sensor without Slits.

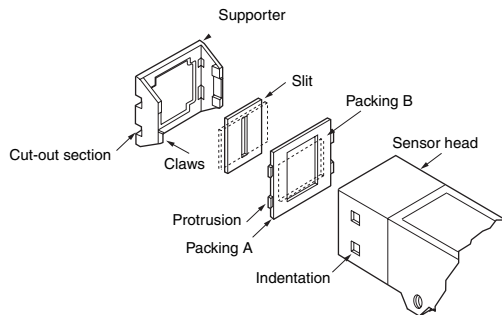

**Sensor with Slits**

Applicable Photoelectric Sensor Model	E3S-5E4, -5E41				E3S-2E4, -2E41		
	E39-S1				E39-S2		
	0.5 mm	1 mm	2 mm	4 mm	0.5 mm	1 mm	2 mm
Sensing distance	230 mm	580 mm	1200 mm	2500 mm	170 mm	420 mm	820 mm
Sensing object	0.5 mm	1 mm	2 mm	4 mm	0.5 mm	1 mm	2 mm
Degree of protection	IP60						

**● Sensors with Open-collector Outputs**

**Sensors with Open-collector Outputs**

Type	Output type	Output transistor	Rated current output	Switching current	Output protection circuit
E	Voltage or current output	NPN	1.5 to 4 mA	80 mA max. (sinking)	Provided against an increase in the residual output voltage
C	Open-collector output	NPN	—	100 mA max. (sinking)	Provided: Output transistor cutoff
B	Open-collector output	PNP	—	100 mA max. (sourcing)	Provided: Output transistor cutoff

The model numbers are as follows:

- Example:  
 E3S-DS10E4 (E type)  
 E3S-DS1C4 (C type)  
 E3S-DS1B4 (B type)

**C4 (C41, C42) Sensors**

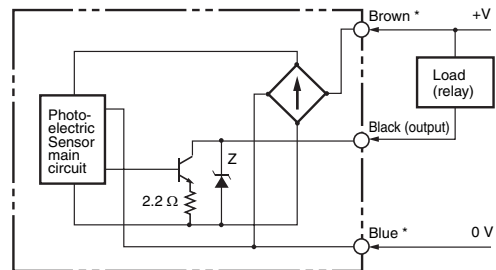

**C4 (B41, B42) Sensors**

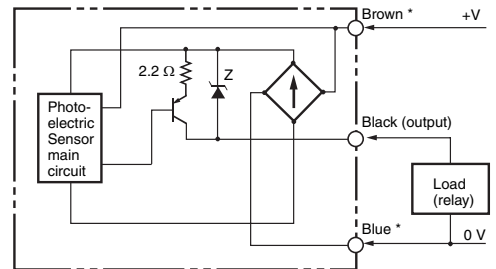

Z: Zener diode (Vz = 30 V)

\* The operation mode depends on the wiring of the brown and blue lines.

- Note 1. Only C42 models with die-cast cases are available.  
 2. The Emitter for a Through-beam C4-type Sensor is the same as the Emitter for an E4-type Sensor. (E.g., E3S-5LE4)  
 3. When a C- or B- type Sensor experiences a load short-circuit or overload, the output transistor will be turned OFF. Check the load conditions before turning the power back ON.



● **Sensors with Different Orientations**

The E3S-5, E3S-DS30, and E3S-R2 that sense in different directions can be made.

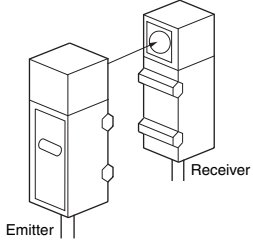
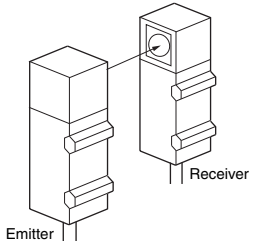
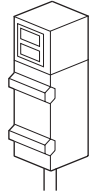
Sensing method	Sensing direction
Through-beam	<p>E3S-5E43</p> 
	<p>E3S-5E44</p> 
Retro-reflective Diffuse-reflective	<p>E3S-DS30E43 E3S-R2E43</p> 

Dimensions

Unless otherwise specified, the tolerance class IT16 is used for dimensions in this data sheet.

General-purpose Sensors

E3S-2E4

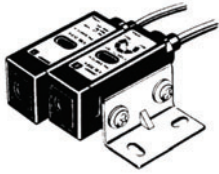

4-dia. vinyl-insulated round cable with 2/3 conductors  
(Conductor cross section: 0.2 mm<sup>2</sup>,  
Insulator diameter: 1.1 mm),  
Standard length: 2 m  
Weight: Emitter and Receiver, 80 g each

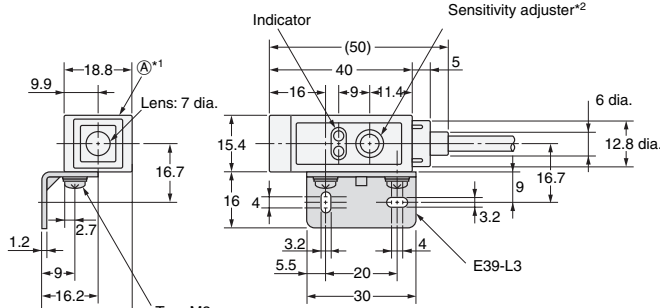

\*1 The mounting bracket can also be used on side (A).  
\*2 Receiver only.

E3S-2E41

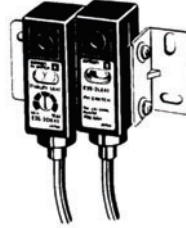

4-dia. vinyl-insulated round cable with 2/3 conductors  
(Conductor cross section: 0.2 mm<sup>2</sup>, Insulator diameter: 1.1 mm),  
Standard length: 2 m  
Weight: Emitter and Receiver, 80 g each

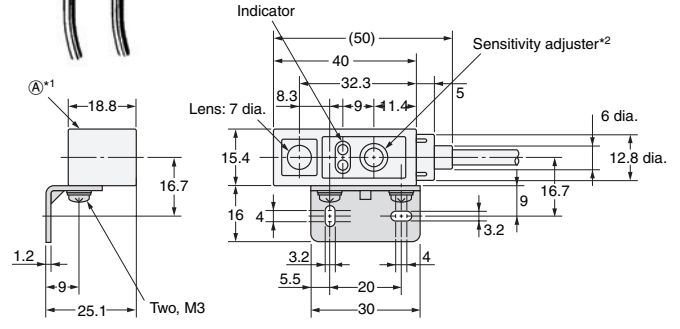

\*1 The mounting bracket can also be used on side (A).  
\*2 Receiver only.

E3S-5E4

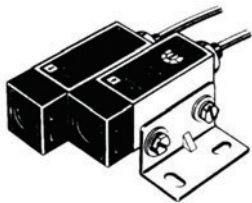

4-dia. vinyl-insulated round cable with 2/3 conductors  
(Conductor cross section: 0.2 mm<sup>2</sup>,  
Insulator diameter: 1.1 mm),  
Standard length: 2 m  
Weight: Emitter and Receiver, 155 g each

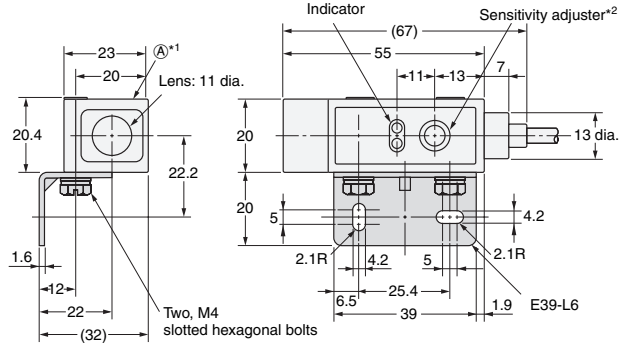

\*1 The mounting bracket can also be used on side (A).  
\*2 Receiver only.

E3S-5E41

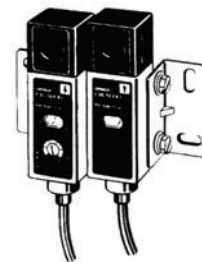

4-dia. vinyl-insulated round cable with 2/3 conductors  
(Conductor cross section: 0.2 mm<sup>2</sup>, Insulator diameter: 1.1 mm),  
Standard length: 2 m  
Weight: Emitter and Receiver, 165 g each

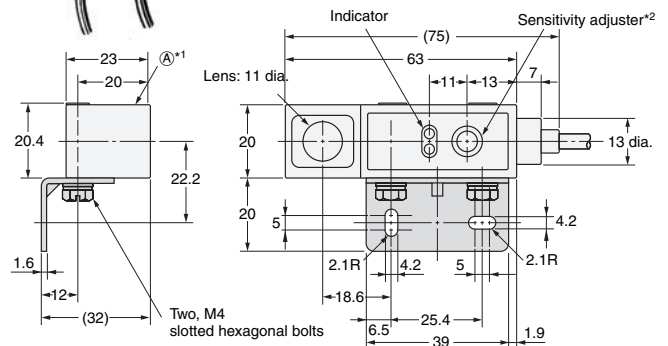

\*1 The mounting bracket can also be used on side (A).  
\*2 Receiver only.

Note: Models numbers for Through-beam Sensors (E3S-□E4, E3S-□E41) are for sets that include both the Emitter and Receiver. The model number of the Emitter is expressed by adding "L" to the set model number (example: E3S-2LE4), the model number of the Receiver, by adding "D" (example: E3S-2DE4.) Refer to Ordering Information to confirm model numbers for Emitter and Receivers.

**E3S-DS10E4**

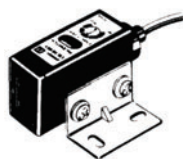

4-dia. vinyl-insulated round cable with 3 conductors  
(Conductor cross section: 0.2 mm<sup>2</sup>, Insulator diameter: 1.1 mm),  
Standard length: 2 m  
Weight: Approx. 80 g

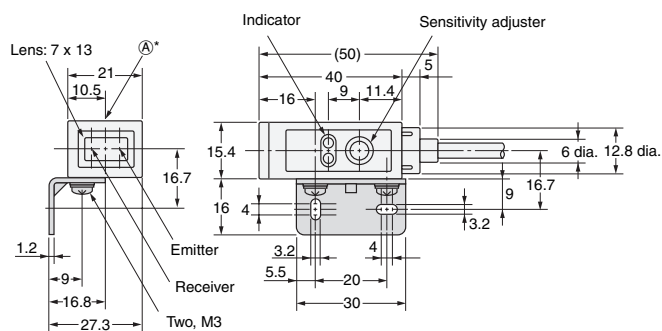

\* The mounting bracket can also be used on side (A).

**E3S-DS10E41**

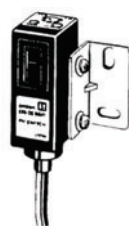

4-dia. vinyl-insulated round cable with 3 conductors  
(Conductor cross section: 0.2 mm<sup>2</sup>, Insulator diameter: 1.1 mm),  
Standard length: 2 m  
Weight: Approx. 80 g

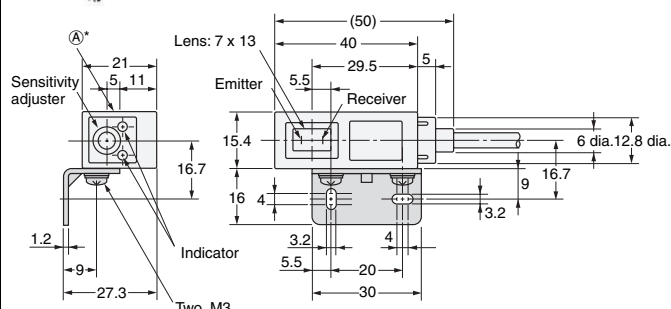

\* The mounting bracket can also be used on side (A).

**E3S-R2E4**  
**E3S-DS30E4**

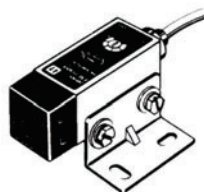

4-dia. vinyl-insulated round cable with 3 conductors  
(Conductor cross section: 0.2 mm<sup>2</sup>, Insulator diameter: 1.1 mm),  
Standard length: 2 m  
Weight: Approx. 155 g

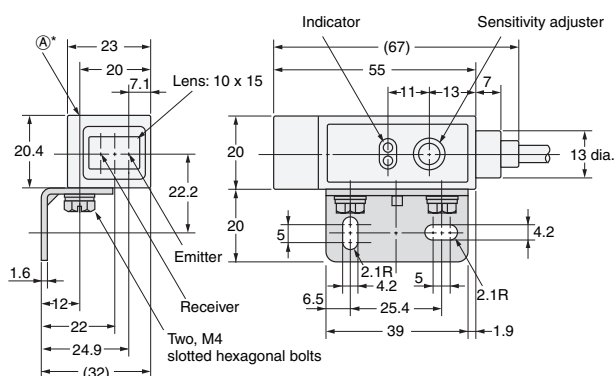

\* The mounting bracket can also be used on side (A).

**E3S-R2E41**  
**E3S-DS30E41**

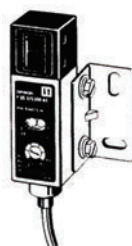

4-dia. vinyl-insulated round cable with 3 conductors  
(Conductor cross section: 0.2 mm<sup>2</sup>, Insulator diameter: 1.1 mm),  
Standard length: 2 m  
Weight: Approx. 165 g

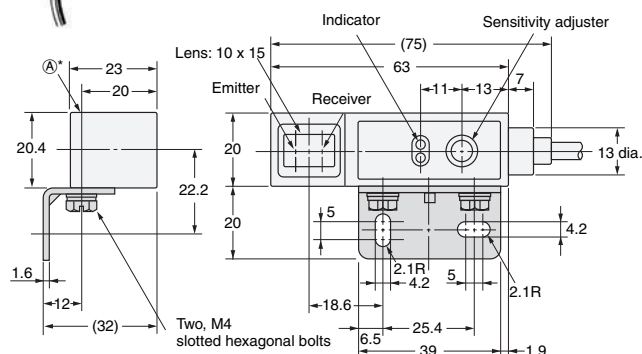

\* The mounting bracket can also be used on side (A).

**E3S-R2E42**



4-dia. vinyl-insulated round cable with 3 conductors  
(Conductor cross section: 0.2 mm<sup>2</sup>, Insulator diameter: 1.1 mm),  
Standard length: 2 m  
Weight: Approx. 165 g

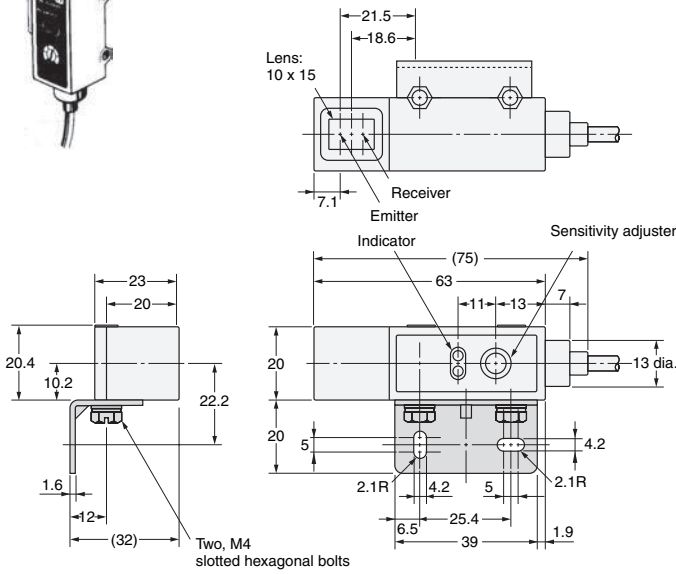

**E3S-LS10XE4**  
**E3S-LS20XE4**

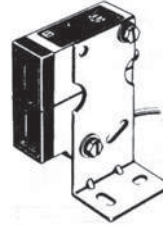

4-dia. vinyl-insulated round cable with 3 conductors  
(Conductor cross section: 0.2 mm<sup>2</sup>, Insulator diameter: 1.1 mm),  
Standard length: 2 m  
Weight: Approx. 225 g

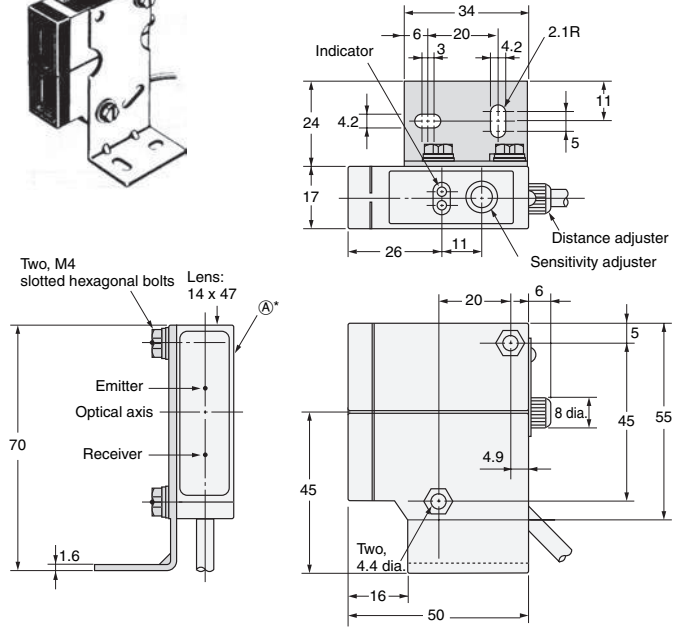

\* The mounting bracket can also be used on side (A).

**Mounting Hole Dimensions**

**E3S-2E4**  
**E3S-2E41**  
**E3S-DS10E4**  
**E3S-DS10E41**

**E3S-LS10XE4**  
**E3S-LS20XE4**

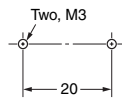

**E3S-5E4**  
**E3S-5E41**  
**E3S-R2E4**  
**E3S-R2E41 (42)**

**E3S-DS30E4**  
**E3S-DS30E41**

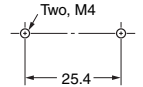

Accessories (Order Separately)

Special Mounting Bracket

E39-L2

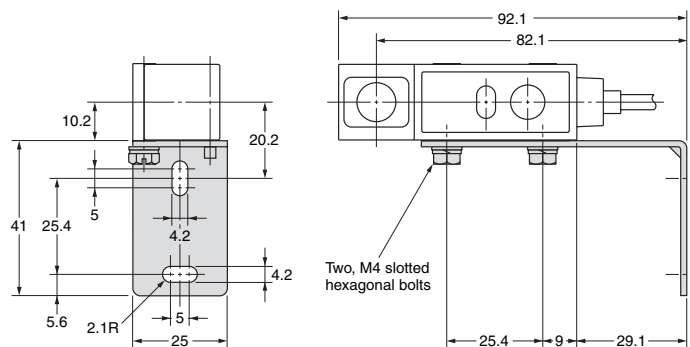
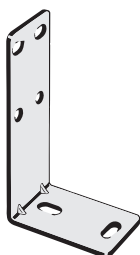

Mounting Holes

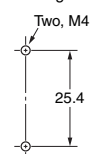

Applicable models:  
E3S-5E41  
E3S-R2E41  
E3S-DS30E41

E39-L4

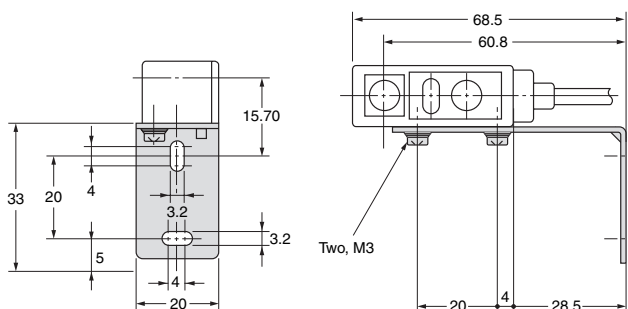
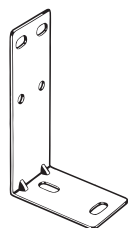

Mounting Holes

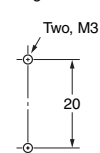

Applicable models:  
E3S-2E41  
E3S-DS10E41

Reflector

E39-R1

(Provided with the E3S-R2E4(41) Retro-reflective Reflector.)



Material:  
Reflective surface: Acrylic  
Rear surface: ABS

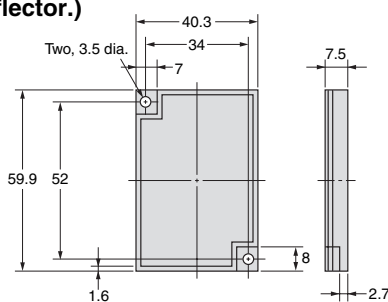

Sensitivity Adjuster (Provided)

E39-G1

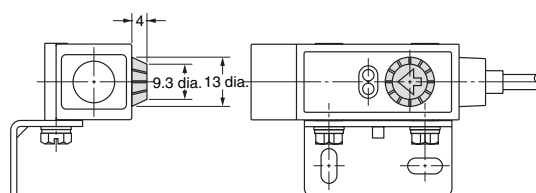

Applicable models:  
Provided with the E3S-5E4(41), E3S-DS30E4(41), E3S-R2E4(41).  
Note: Cannot be used for the E3S-DS10E4 (41).

**Slit (Order Separately)**

**E39-S2**

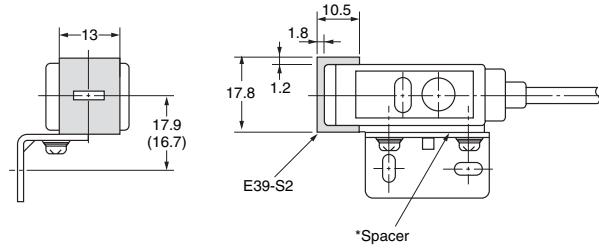
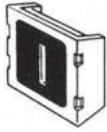

Slit	E39-S2
Applicable Sensors	E3S-2E4 E3S-2E41

- Note 1. Three sets of slits are provided:  
6.5 x 0.5 mm, 6.5 x 1 mm and 6.5 x 2 mm
2. One set consists of two slits, one each for the Emitter and Receiver.

**E39-S1**

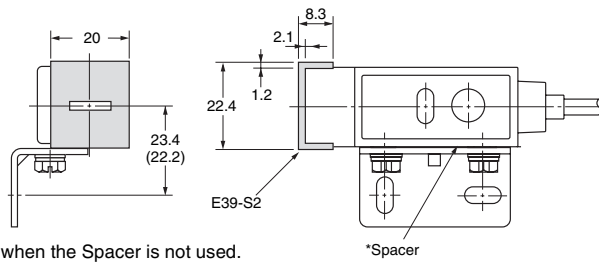
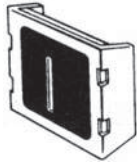

Slit	E39-S1
Applicable Sensors	E3S-5E4 E3S-5E41

- Note 1. Four sets of slits are provided:  
11 x 0.5 mm, 11 x 1 mm, 11 x 2 mm, and 11 x 4 mm
2. One set consists of two slits, one each for the Emitter and Receiver.

Note: The dimensions in parentheses are for when the Spacer is not used.

\* With the E3S-2E4 (41), use the Spacer as shown in the figure above so that the supporter and Mounting Bracket will not be struck when the optical axis is adjusted.

With the E3S-5E4 (41), the Spacer is not particularly required. Use the Spacer, however, to directly mount both the E3S-2E4 (41) and -5E4 (41).

In the interest of product improvement, specifications are subject to change without notice.

## Terms and Conditions Agreement

### Read and understand this catalog.

Please read and understand this catalog before purchasing the products. Please consult your OMRON representative if you have any questions or comments.

### Warranties.

(a) Exclusive Warranty. Omron's exclusive warranty is that the Products will be free from defects in materials and workmanship for a period of twelve months from the date of sale by Omron (or such other period expressed in writing by Omron). Omron disclaims all other warranties, express or implied.

(b) Limitations. OMRON MAKES NO WARRANTY OR REPRESENTATION, EXPRESS OR IMPLIED, ABOUT NON-INFRINGEMENT, MERCHANTABILITY OR FITNESS FOR A PARTICULAR PURPOSE OF THE PRODUCTS. BUYER ACKNOWLEDGES THAT IT ALONE HAS DETERMINED THAT THE PRODUCTS WILL SUITABLY MEET THE REQUIREMENTS OF THEIR INTENDED USE.

Omron further disclaims all warranties and responsibility of any type for claims or expenses based on infringement by the Products or otherwise of any intellectual property right. (c) Buyer Remedy. Omron's sole obligation hereunder shall be, at Omron's election, to (i) replace (in the form originally shipped with Buyer responsible for labor charges for removal or replacement thereof) the non-complying Product, (ii) repair the non-complying Product, or (iii) repay or credit Buyer an amount equal to the purchase price of the non-complying Product; provided that in no event shall Omron be responsible for warranty, repair, indemnity or any other claims or expenses regarding the Products unless Omron's analysis confirms that the Products were properly handled, stored, installed and maintained and not subject to contamination, abuse, misuse or inappropriate modification. Return of any Products by Buyer must be approved in writing by Omron before shipment. Omron Companies shall not be liable for the suitability or unsuitability or the results from the use of Products in combination with any electrical or electronic components, circuits, system assemblies or any other materials or substances or environments. Any advice, recommendations or information given orally or in writing, are not to be construed as an amendment or addition to the above warranty.

See <http://www.omron.com/global/> or contact your Omron representative for published information.

### Limitation on Liability; Etc.

OMRON COMPANIES SHALL NOT BE LIABLE FOR SPECIAL, INDIRECT, INCIDENTAL, OR CONSEQUENTIAL DAMAGES, LOSS OF PROFITS OR PRODUCTION OR COMMERCIAL LOSS IN ANY WAY CONNECTED WITH THE PRODUCTS, WHETHER SUCH CLAIM IS BASED IN CONTRACT, WARRANTY, NEGLIGENCE OR STRICT LIABILITY.

Further, in no event shall liability of Omron Companies exceed the individual price of the Product on which liability is asserted.

### Suitability of Use.

Omron Companies shall not be responsible for conformity with any standards, codes or regulations which apply to the combination of the Product in the Buyer's application or use of the Product. At Buyer's request, Omron will provide applicable third party certification documents identifying ratings and limitations of use which apply to the Product. This information by itself is not sufficient for a complete determination of the suitability of the Product in combination with the end product, machine, system, or other application or use. Buyer shall be solely responsible for determining appropriateness of the particular Product with respect to Buyer's application, product or system. Buyer shall take application responsibility in all cases.

NEVER USE THE PRODUCT FOR AN APPLICATION INVOLVING SERIOUS RISK TO LIFE OR PROPERTY OR IN LARGE QUANTITIES WITHOUT ENSURING THAT THE SYSTEM AS A WHOLE HAS BEEN DESIGNED TO ADDRESS THE RISKS, AND THAT THE OMRON PRODUCT(S) IS PROPERLY RATED AND INSTALLED FOR THE INTENDED USE WITHIN THE OVERALL EQUIPMENT OR SYSTEM.

### Programmable Products.

Omron Companies shall not be responsible for the user's programming of a programmable Product, or any consequence thereof.

### Performance Data.

Data presented in Omron Company websites, catalogs and other materials is provided as a guide for the user in determining suitability and does not constitute a warranty. It may represent the result of Omron's test conditions, and the user must correlate it to actual application requirements. Actual performance is subject to the Omron's Warranty and Limitations of Liability.

### Change in Specifications.

Product specifications and accessories may be changed at any time based on improvements and other reasons. It is our practice to change part numbers when published ratings or features are changed, or when significant construction changes are made. However, some specifications of the Product may be changed without any notice. When in doubt, special part numbers may be assigned to fix or establish key specifications for your application. Please consult with your Omron's representative at any time to confirm actual specifications of purchased Product.

### Errors and Omissions.

Information presented by Omron Companies has been checked and is believed to be accurate; however, no responsibility is assumed for clerical, typographical or proofreading errors or omissions.

2015.9

In the interest of product improvement, specifications are subject to change without notice.

**OMRON Corporation**  
Industrial Automation Company

<http://www.ia.omron.com/>

(c)Copyright OMRON Corporation 2015 All Right Reserved.